

## Classroom Computer Lab Designs

<http://www.brighthub.com/computing/hardware/articles/52714.aspx>

### Classroom Computer Lab Layout

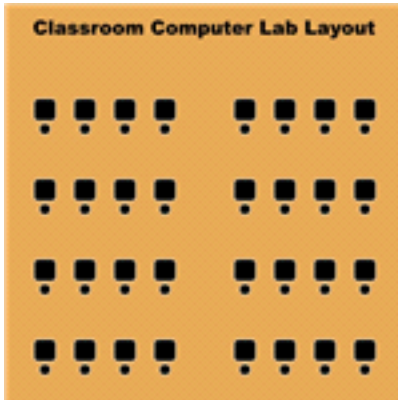

The classic classroom computer lab design serves as the default layout in many High School and Colleges. However, it does have two major advantages. First, it serves as a great instruction room where students learn computer topics from an instructor at the front of the room. With everyone facing the same direction, it allows instructors to see the faces of the students with which to read

non-verbal cues as to whether students are learning the material or need more help. Second, it is similar to the layout of other classroom environment emphasizing that the students are there to learn.

One disadvantage of the classroom layout is the need to disturb other students along the rows of computers as students enter and exit the lab. For labs where students are coming and going, the classroom layout is not ideal. In addition, the classroom layout is not conducive to team work. It is difficult for students to work together, especially on collective projects and in peer-assist teaching models.

### Four-Leaf Clover Computer Lab Layouts

#### Four-Leaf Clover Computer Lab Layout

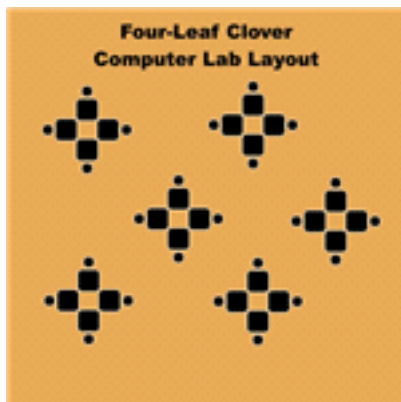

The four-leaf clover design offers the most privacy for students and reduces to a minimum the possibility of cheating during tests or exercises. It also eliminates the need for students to disturb others when entering and exiting the lab and allows instructors to go from student to student to address individual problems and concerns.

One disadvantage of the four-leaf clover design has to do with attention spans. When students are sitting at their own computers, instructors will not be able to see what each student is doing at his/her workstation. Students may not be paying attention to lessons or may be surfing to inappropriate websites in labs equipped with Internet access.

Four-leaf clover designs can also be more expensive if each computer sits on its own table. Some computer lab furniture is made specifically for this design offering space for four computers on one table or desk.

## U-Shaped Computer Lab Designs

**U-Shaped Computer Lab Layout**  
The U-shaped computer lab layout encourages engagement between instructors and students. Instructors can enter the U and engage with students one-on-one. This design also serves as the most conducive layout for computer maintenance as technicians do not have to disturb others to gain access to the computers. In addition, students will not interfere with other students' work while entering and exiting the lab.

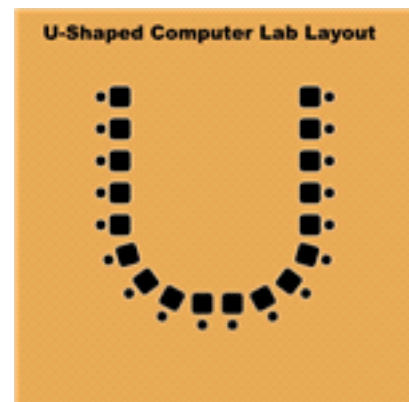

Unfortunately, the U-shaped design offers little opportunity for instructors to monitor what students are doing and looking at on their monitors. This design is not compatible with test taking and requires many assistants to monitor students. Furthermore, this design often takes up more space than other layouts.

**Inverted U-Shaped Computer Lab Layouts**

## **Inverted U-Shaped Computer Lab**

**Layout** Like the U-shaped layout, the Inverted U-shape also offers engagement between instructors and students. In addition, the layout allows for the most convenient method of monitoring students. For individual learning, this layout minimizes the distance instructors must walk to move from workstation to workstation and student to student.

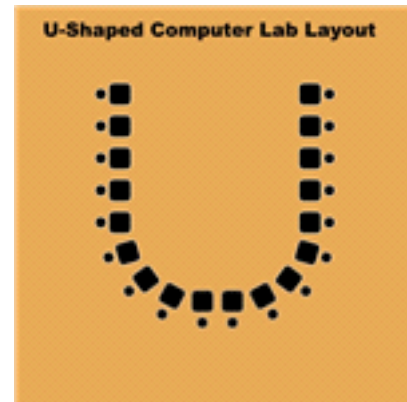

Like the classroom layout, traffic into and out of the Inverted U-shape can become constrictive especially when all of the students must enter and exit at the same time. This congestion is reduced if students are entering and exiting individually as in an open lab paradigm where students can come and go as they please. In addition, this layout takes up the same amount of space as the U-shaped design. If space is not a consideration, either of the U-shaped layouts is appropriate.

### **Conclusion**

There are many options when designing the layout of a computer lab. The key is to make sure form is following function. Thought and planning at the beginning of designing the lab ensures that students and instructors are satisfied with what the lab offers. Choosing a sub-optimal layout can negatively affect student learning and reduce the engagement between instructors and students.

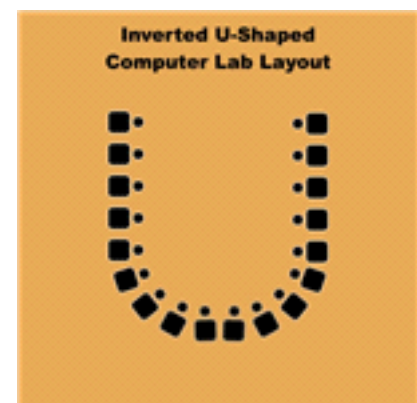

Read more:

<http://www.brighthub.com/computing/hardware/articles/52714.aspx#ixzz0cys6J43x>